

Alpha INOX



PNEUMATIC RACK & PINION ACTUATORS
90° - 120° - 180°



March 2020

ALPHAIR PNEUMATIC ACTUATORS

AISI 316 STAINLESS STEEL

90° - STD Series

120° - Y Series

180° - X Series

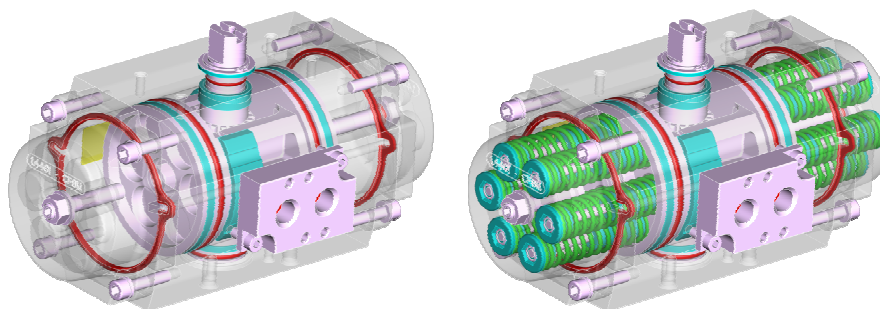

ALPHAIR pneumatic actuators are made by the best manufacture experience on design, material, machining, assembly. The internal rotation adjusting system is free of side-loads on pistons, shaft and body.

HEAVY DUTY, MAXIMUM LIFETIME!

ALPHAIR pneumatic actuators are compact, heavy and reliable. Easy assembly/substitution on every kind of valve.

STANDARD VERSION FEATURES

- **Extruded Stainless Steel type A182 - F316 - EN 10088/3 - 1.4401 Body**, inside surface finish Ra=0,4-0,6.
- **EN AB 46100 T6 die-casted Aluminium alloy Pistons**, 15 micron Anodizing as standard.
- **Micro-casted Stainless Steel A182 - F316 - EN 10088/3 - 1.4401 Pistons**, on request.
- **Micro-casted Stainless Steel A182 - F316 - EN 10088/3 - 1.4401 Covers**.
- **Forged Stainless Steel type AISI 316 (A4) Shaft**.
- AISI 316 (A4) Stainless Steel Screws.
- NBR nitrile rubber seals. FPM/FKM or SILICONE on request.
- Acetalic resin + 20% PTFE bearings, for low friction, easily replaceable for maintenance. PA66 or LEXAN on request.
- Pre-compressed Spring Cartridges, easily replaceable for maintenance, 60-80 micron polyester painted.
- High performances Syntetic Grease as standard grease. Special grease supplied for HIGH/LOW/VERY LOW temperatures.
- External standard electropolishing. Mirror polishing on request for chemical, pharmaceutical, food applications.
- Double/triple lower drilling for valve fastening and centering, according to **ISO 5211-DIN 3337 Standards**.
- Double square lower female shaft key (starlike), according to **ISO 5211-DIN 3337 Standards** for assembly on valves with square key on line (0°) and diagonal key (45°).
- Solenoid connections according to **NAMUR VDI/VDE-3845 Standards**.
- Top drilling for accessories fastening, and upper shaft end according to **NAMUR VDI/VDE-3845 Standards**.
- Position indicator on request, enabling switch-box assembly on top.
- Aluminium adhesive nameplates, with progressive serial number punched.
- Lubrification carried out by the manufacturer, guaranteed for min. 1.000.000 operations.
- Running test and 100% seal test carried out with electronic equipment and certification of each individual product.
- Standard execution for temperatures from -20°C to +80°C (optional, special execution for extreme temperatures).
- Conformity for use in explosive environment: II M2 - II 2GD c Tmax 95°C protection type.
- According to EN 15714-3 design and manufacture standard requirements.



SUPPLY	TEMPERATURE RANGE	FEEDING PRESSURE	ROT. ADJUSTMENT
Dry or lubricated 50 um filtered compressed air	Standard -20° +80°C (-4 +175°F) HIGH Temperature -20° +150°C (-4 + 300°F) LOW Temperature -40° +80°C (-40 + 175°F) VERY LOW Temperature -60° +80°C (-76 + 175°F)	Aluminium pistons 8 bar/120 psi continuous working 10 bar/142 psi MAXIMUM Stainless Steel pistons 15 bar/225 psi continuous working 18 bar/260 psi MAXIMUM	+/- 5° in both OPENING and CLOSING position

DOUBLE ACTING TORQUE RATINGS IN Nm

STD Series = 90°
Y Series = 120°
X Series = 180°

	AIR SUPPLY IN BAR													
	Aluminium pistons							Stainless Steel pistons						
	3	4	5	6	7	8	9	10	11	12	13	14	15	
AP 032-A	-	5,0	6,3	7,6	8,8	10,0	11,4	12,6	13,9	15,1	16,4	17,7	18,9	
AP 042-A	6,5	8,7	10,9	13,0	15,2	17,3	19,5	21,7	23,9	26,0	28,2	30,4	32,6	
AP 050-A	9,2	12,3	15,4	18,5	21,5	24,6	27,7	30,8	33,8	36,9	40,0	43,1	46,2	
AP 063-A	16,5	22,0	27,5	33,0	38,5	44,0	49,5	55,0	60,5	66,0	71,5	77,0	82,5	
AP 075-A	35,1	46,8	58,5	70,2	81,9	93,6	105,3	117,0	128,7	140,4	152,1	163,8	175,5	
AP 085-A	53,4	71,2	89,0	106,9	124,7	142,4	160,3	178,1	195,9	213,7	231,5	249,3	267,1	
AP 100-A	83,2	110,9	138,6	166,4	194,1	221,8	249,5	277,3	305,0	332,8	360,5	388,2	416,0	
AP 115-A	137,2	183,0	228,7	274,5	320,2	366,0	411,7	457,5	503,2	549,0	594,8	640,5	686,3	
AP 125-A	180,5	240,7	300,9	361,1	421,2	481,4	541,6	601,8	662,0	722,2	782,3	842,5	902,7	
AP 145-A	260,1	346,8	433,5	520,2	606,9	693,6	780,3	867,0	953,7	1040	1127	1214	1300	

SINGLE ACTING TORQUE RATINGS IN Nm

STD Series = 90°

	SPRING SET	AIR SUPPLY IN BAR												SPRING TORQUE	
		3		4		5		6		7		8		90°	0°
		0°	90°	0°	90°	0°	90°	0°	90°	0°	90°	0°	90°		
AP 042-A	SR 3/3 SR 4/4	-	-	-	-	7,1	4,1	9,3	6,3	11,5	8,5	13,7	10,7	6,8	3,8
AP 050-A	SR 3/3	5,7	3,5	8,9	6,6	12,0	9,6	15,1	12,7	18,1	15,7	21,2	18,8	5,7	3,5
	SR 4/4			7,7	4,7	10,8	7,7	13,9	10,8	16,9	13,8	20,0	16,9	7,7	4,7
	SR 5/5					9,6	5,8	12,7	8,9	15,7	11,9	18,8	15,0	9,6	5,8
	SR 6/6					8,4	3,9	11,5	7,0	14,5	10,0	17,6	13,1	11,5	7,0
AP 063-A	SR 3/3	9,4	6,3	14,9	11,7	20,4	17,2	25,9	22,7	31,4	28,2	36,9	33,7	10,2	7,2
	SR 4/4			12,3	8,3	17,8	13,8	23,3	19,3	28,8	24,8	34,3	30,3	13,7	9,7
	SR 5/5					15,4	10,4	20,9	15,9	26,4	21,4	31,9	26,9	17,1	12,1
	SR 6/6					13,0	7,0	18,5	12,5	24,0	18,0	29,5	23,5	20,5	14,5
AP 075-A	SR 3/3	22,5	12,6	34,2	24,4	46,0	36,1	57,7	47,8	69,4	59,5	81,1	71,2	22,5	12,6
	SR 4/4			30,0	16,9	41,8	28,6	53,5	40,3	65,2	52,0	76,9	63,7	30,0	16,9
	SR 5/5					37,6	21,1	49,3	32,8	61,0	44,5	72,7	56,2	37,6	21,1
	SR 6/6					33,4	13,6	45,1	25,3	56,8	37,0	68,5	48,7	45,1	25,3
AP 085-A	SR 3/3	34,5	18,9	52,4	36,7	70,2	54,5	88,0	72,3	105,8	90,1	123,6	107,9	34,5	18,9
	SR 4/4			46,1	25,2	63,9	43,0	81,7	60,8	99,5	78,6	117,3	96,4	46,1	25,2
	SR 5/5					57,6	31,5	75,4	49,3	93,2	67,1	111,0	84,9	57,6	31,5
	SR 6/6					51,5	20,0	69,1	37,8	86,9	55,6	104,7	73,4	69,1	37,8
AP 100-A	SR 3/3	53,2	30,0	80,9	57,7	108,7	85,4	136,4	113,1	164,1	140,8	191,8	168,5	53,2	30,0
	SR 4/4			70,9	40,0	98,7	67,7	126,4	95,4	154,1	123,1	181,8	150,8	70,9	40,0
	SR 5/5					88,7	50,0	116,4	77,7	144,1	105,4	171,8	133,1	88,7	50,0
	SR 6/6					78,7	32,2	106,4	60,0	134,1	87,7	161,8	115,4	106,4	60,0
AP 115-A	SR 3/3	84,3	53,0	130,0	98,8	175,8	144,5	221,6	190,3	267,3	236,0	313,0	281,7	84,3	53,0
	SR 4/4			112,3	70,7	158,1	116,4	203,9	162,2	249,6	207,9	295,3	253,6	112,3	70,7
	SR 5/5					140,4	88,3	186,2	134,1	231,9	179,8	277,6	225,5	140,4	88,3
	SR 6/6					122,7	60,2	168,5	106,0	214,2	151,7	259,9	197,4	168,5	106,0
AP 125-A	SR 3/3	116,8	63,7	177,0	123,9	237,3	184,1	297,5	244,2	357,6	304,3	417,7	364,4	116,8	63,7
	SR 4/4			155,7	85,0	216,0	145,2	276,2	205,3	336,3	265,4	396,4	325,5	155,7	85,0
	SR 5/5					194,7	106,3	254,9	166,4	315,0	226,5	375,1	286,6	194,7	106,3
	SR 6/6					173,4	67,4	233,6	127,5	293,7	187,6	353,8	247,7	233,6	127,5
AP 145-A	SR 3/3	158,0	92,0	245,0	179,0	332,0	265,0	418,0	352,0	505,0	439,0	592,0	526,0	158,0	102,0
	SR 4/4			211,0	123,0	298,0	210,0	384,0	269,0	471,0	383,0	558,0	470,0	224,0	136,0
	SR 5/5					264,0	154,0	350,0	240,0	437,0	327,0	524,0	414,0	280,0	170,0
	SR 6/6					230,0	98,0	316,0	184,0	403,0	271,0	490,0	358,0	336,0	204,0

Torque by air

Torque by springs

DIMENSIONS - European sizes in millimetres

**STD Series = 90°
Y Series = 120°
X Series = 180°**

VDI\VDE-3854

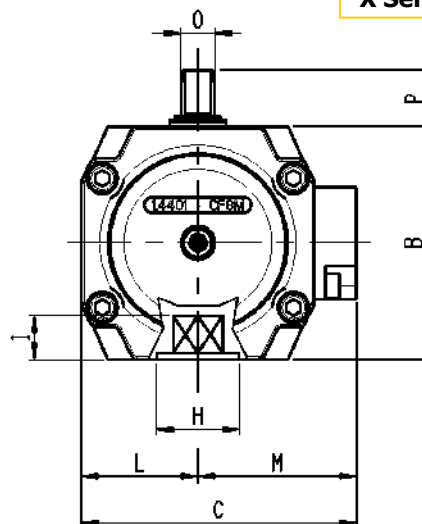
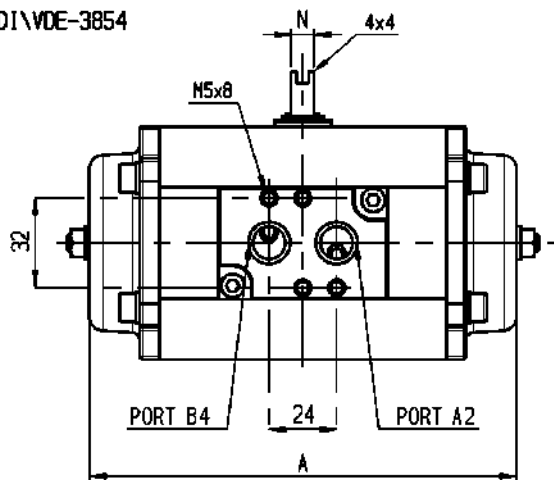

VDI\VDE-3854

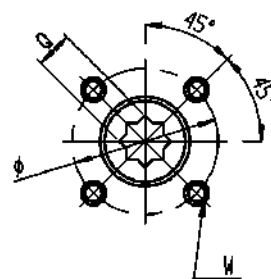
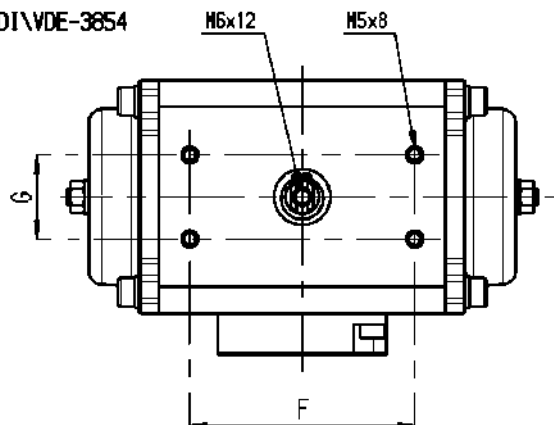

ISO 5211

TYPE											
	AP 032-A	AP 042-A	AP 050-A	AP 063-A	AP 075-A	AP 085-A	AP 100-A	AP 115-A	AP 125-A	AP 145-A	
A 90°	104	140	139	152	205	230	275	307	359	388	
AY 120°	116	154	163	180	239	273	322	363	424	-	
AX 180°	149	190	196	214	297	332	398	451	518	-	
B	45	57	68	83	100	110	125	142	155	175	
C	49,5	71	79	98	113	123	140	161	173	200	
VDI/VDE 3845 F x G	50 x 25	80 x 30						130 x 30			
H	- / 30	25 / 30	25 / 30	25	35	40	40	55	55	70	
L	23,5	30,5	34,5	41,5	49	54	62,5	73	79	95	
M	26	40,5	44,5	56,5	64	69	77,5	88	94	105	
Port A2 Port B4	1/8" GAS NPT			1/4" GAS NPT							
N x O	8 x 12				14 x 18			27 x 36			
VDI/VDE 3845 P	20						30				
ISO 5211 square Q x I	9 x 10	11 x 13	11 x 13	14 x 16	17 x 20	17 x 20	22 x 25	22 x 25	27 x 30	27 x 30	
ISO 5211 valve flange	F03/05	F03/05	F03/05	F03/05/07	F05/07	F05/07	F05/07/10	F07/10	F07/10/12	F10/12	
Optional	F04	F04	F04	-	-	-	-	-	-	-	

F ISO 5211 – DIN 3337								
	F03	F04	F05	F07	F10	F12	F14	F16
Ø (W)	Ø 36 (M5x8)	Ø 42 (M5x8)	Ø 50 (M6x9)	Ø 70 (M8x12)	102 (M10x15)	125 (M12x18)	140 (M16x24)	165 (M20x30)

CONSTRUCTION PARTS – SPECIFICATIONS

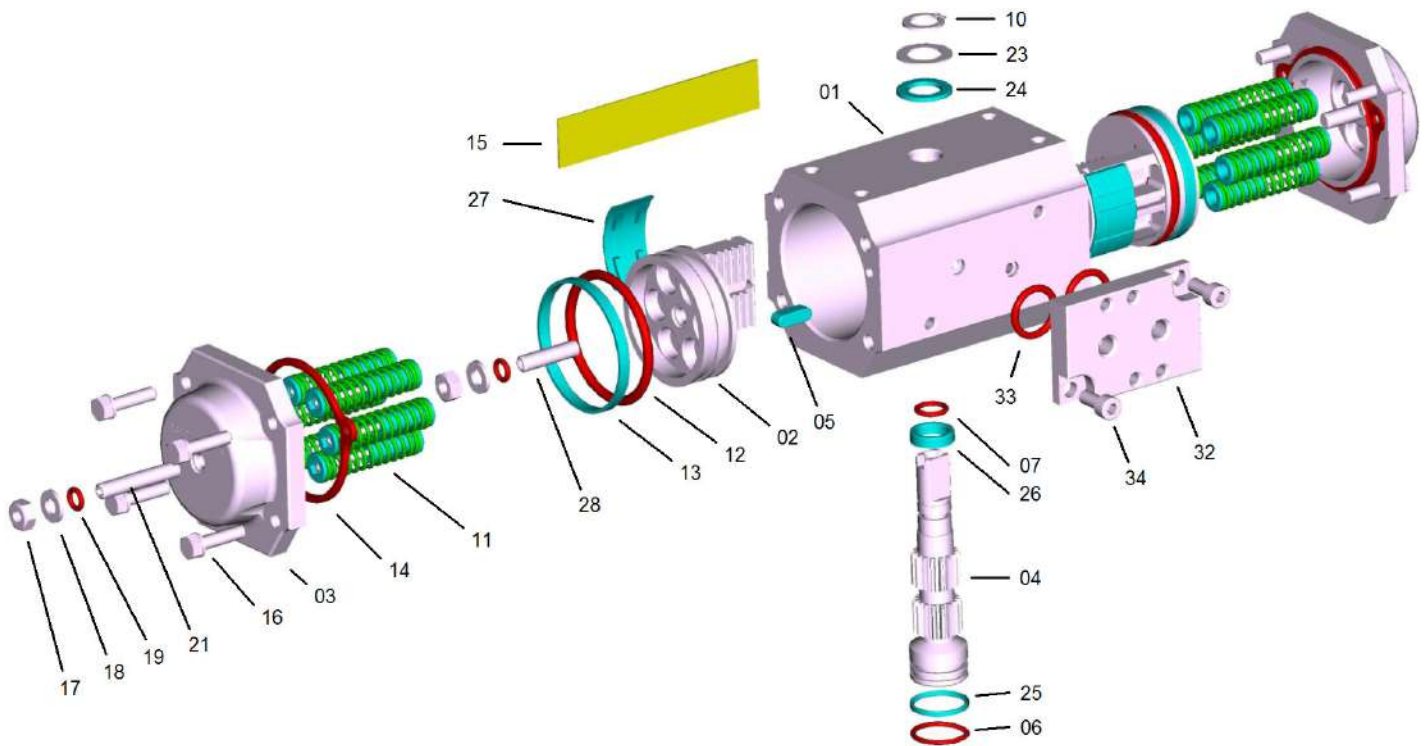



PART	QUANTITY	DESCRIPTION	MATERIAL	SPECIFICATION	FINISHING
1	1	Body	Extruded Stainless Steel	AISI 316 (A4)	EL - MP
2	2	Piston	Aluminium alloy Stainless Steel - optional	EN AB 46100 T6 AISI 316 (A4)	A
3	2	Cover	Microcasted Stainless Steel	AISI 316 (A4)	EL - MP
4	1	Shaft	Microcasted Stainless Steel	AISI 316 (A4)	
5 *	2	Antiejection key	Acetalic resin – PA66 – PA66 – LEXAN		
6 *	1	Lower shaft O-Ring	NBR – FPM/FKM – Silicone – Silicone		
7 *	1	Upper shaft O-Ring	NBR – FPM/FKM – Silicone – Silicone		
10 *	1	Seeger ring	AISI 420		
11	0 - 8 - 12	Spring cartridge	Carbon steel, PA 66, S.S.	C-98	V
12 *	2	Piston O-Ring	NBR – FPM/FKM – Silicone – Silicone		
13 *	2	Piston head bearing	Acetalic resin – PA66 – PA66 – LEXAN		
14 *	2	Cover gasket	NBR - FPM/FKM - Silicone		
15	1	Nameplate	Aluminium		
16	8	Cover fastening screw	Stainless Steel	AISI 316 (A4)	
17	2	Nut	Stainless Steel	AISI 316 (A4)	
18	2	Washer	Stainless Steel	AISI 316 (A4)	
19 *	2	O-Ring	NBR – FPM/FKM – Silicone – Silicone		
21	2	Cover adjustment screw	Stainless Steel	AISI 316 (A4)	
23 *	1	Shaft thrust washer	Stainless Steel	AISI 316 (A4)	
24 *	1	Shaft antifriction washer	Acetalic resin – PA66 – PA66 – LEXAN		
25 *	1	Lower shaft pilot ring	Acetalic resin – PA66 – PA66 – LEXAN		
26 *	1	Upper shaft pilot ring	Acetalic resin – PA66 – PA66 – LEXAN		
27 *	2	Piston bearing	Acetalic resin – PA66 – PA66 – LEXAN		
28	2	Piston adjustment screw	Stainless Steel	AISI 316 (A4)	
32	1	NAMUR plate	Stainless Steel	AISI 316 (A4)	
33	2	O-Ring for NAMUR plate	NBR – FPM/FKM – Silicone – Silicone		
34	2	NAMUR plate screw	Stainless Steel	AISI 316 (A4)	

* **SPARE PARTS SET:** Standard, Special HIGH Temperatures, Special LOW Temperatures, Special VERY-LOW Temperatures

Finishing

A = Anodizing **V** = Painting **EL** = Electropolishing **MP** = Mirror Polishing

SURFACE FINISHING – OPTIONAL

	EL	DESCRIPTION				APPLICATION FIELD
		Body	Covers	Pistons	Shaft	
	standard	Electro polishing	Electro polishing	Anodizing <i>opt. AISI 316 (A4)</i>	Fine milling	- Mines, marine, heavy industry. - High temperatures. - High pressure. - General use.
	Colour	Steel gray	Steel gray	Brown	Steel gray	
	Thickness	-	-	15 µ	-	
	MP	DESCRIPTION				APPLICATION FIELD
		Body	Covers	Pistons	Shaft	
		Mirror polishing	Mirror polishing	Anodizing <i>opt. AISI 316 (A4)</i>	Fine milling	- Cleaning rooms. - Frequent cleaning with detergents. - Caustic soda. - High alkaline solutions. - High acid solutions.
	Colour	Bright steel	Bright steel	Brown	Steel gray	
	Thickness	-	-	15 µ	-	

ELECTRO POLISHING

The standard surface finishing of AISI 316 (A4) Stainless Steel actuators is "ELECTRO POLISHING", suitable for application in general industry where no special care is required. The properties of AISI 316 (A4) Stainless Steel are well known and appreciated both for mechanical and chemical resistance.

- > **Best mechanical resistance and excellent corrosion resistance in mine, marine and the most severe industrial applications.**
- > **The complete case electric conductivity allows an easy grounding for ATEX and critical applications.**

MIRROR POLISHING – OPTIONAL

"MIRROR POLISHING" can be supplied as an optional; it is recommended for use in plants where the maximum cleaning for hygiene purposes is required. This treatment makes the actuator particularly sleek and bright.

- > **Excellent external appearance and easy cleaning surfaces, particularly for chemical, food, pharma and sanitary applications.**

AISI 316 (A4) STAINLESS STEEL PISTONS – OPTIONAL

AISI 316 (A4) Stainless Steel pistons, with its great chemical resistance and mechanical strength, allows a working pressure up to 15 bar also by means of oil and process fluids. They are recommended for special applications such as: marine and chemical environments, food and pharmaceutical industry, high temperature applications.



Via Molino Emili, 16 - 25030 MACLODIO (BS) Italy - Tel. +39 030 97 86 61/2 - Fax +39 030 97 86 63
www.alphair.it - www.alphapompe.it

All rights reserved - Not guaranteed for accuracy - Data subject to change without notice - Older data sheets are invalid

COMPANY WITH QUALITY SYSTEM CERTIFIED BY DNV GL = ISO 9001 =					EN UNI 10204 3.1	СЕРТИФИКАТ  СООТВЕТСТВИЯ
---	---	---	---	---	---	---